

02-1	FLANGE	2	PPG	25A
02	FRONT CASING	1	PPG	φ123.5X87.5
01	MOTOR	1	250W, 2P, 3φ	
NO	PART NAME	Q'TY	MATERIAL	NOTE

11	SET SCREW	2	S435	M6X10
10	HEAXGON HEAD BOLT w/t PLAIN WASHER	6	SUS304	M6X55
09	O. RING	2	FKM	P20
08	O. RING	1	FKM	G110
07	BACK UP RING	1	SUS304	φ98X4.5
06	BEARING	1	CERAMIC	φ25X35
			CARBON	
			RULON	
05	OUTER DRIVE RING	1	ADC-12	φ86X86
04	IMPELLER ASS'Y	1	PPG	
03	REAR CASING	1	PPS	φ123.5X75
NO	PART NAME	Q'TY	MATERIAL	NOTE

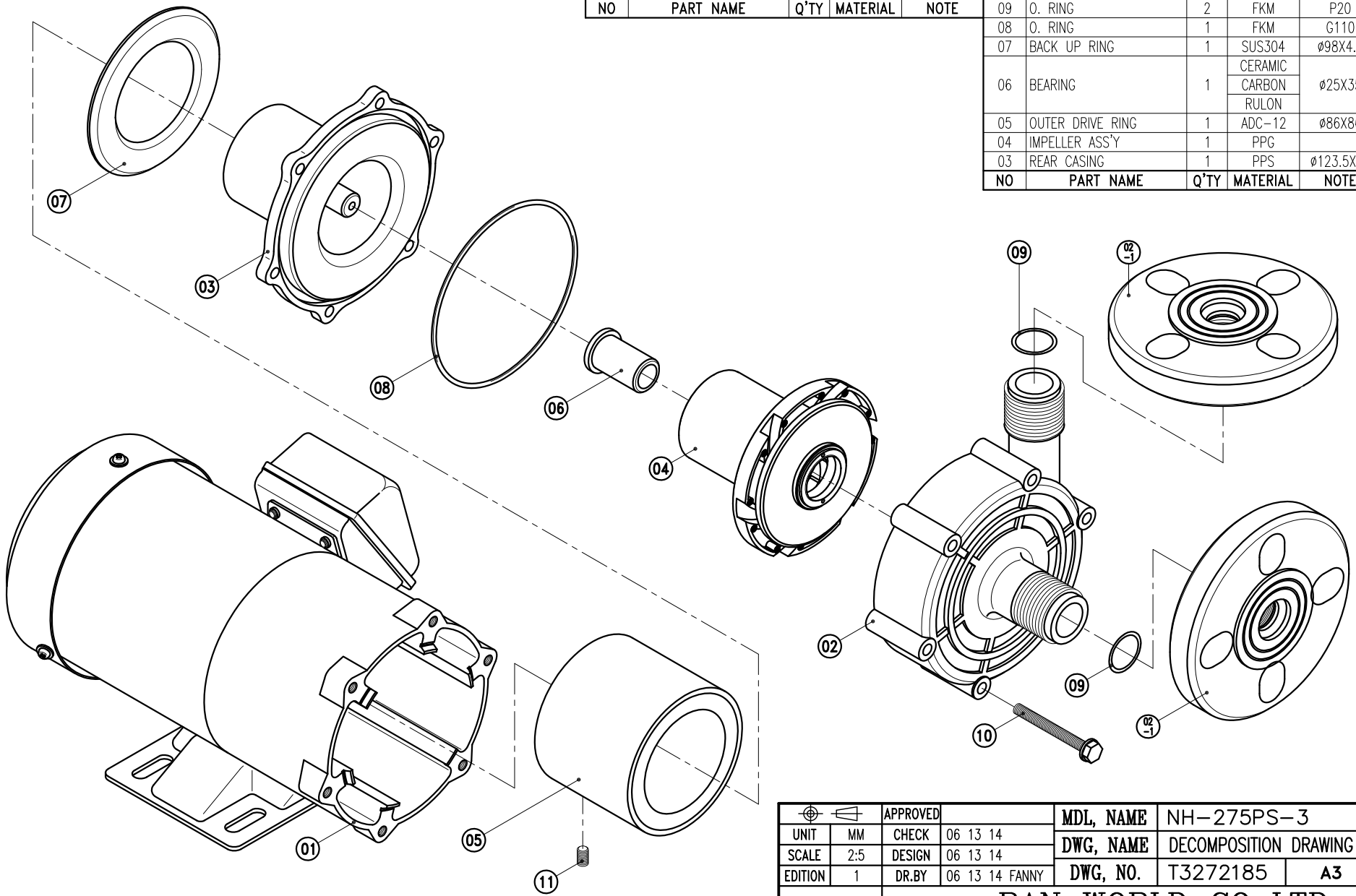

APPROVED		MDL, NAME	NH-275PS-3	
UNIT	MM	CHECK	06 13 14	
SCALE	2:5	DESIGN	06 13 14	
EDITION	1	DR.BY	06 13 14 FANNY	DWG, NO. T3272185
				A3

TPW
HONG YUAN



PAN WORLD CO.,LTD.
パンワールド株式会社