

03-1	REAR THRUST PAD	1	ETFE			04-4	IMPELLER COVER	1	ETFE	∅76X6	P2451044	08	SET SCREW	2	S435	M4X5	P9119420
03	REAR CASING	1	ETFE	∅91X59.5	P2301047	04-3	INNER MAGNET	1	FERRITE	∅36X∅17X30	P2449487	07	SCREW,CROSS RECESS HEAD w/t P.W.(∅10X∅5.3Xt1)	6	SUS304	M5X28	P9111136
02-1	FRONT THRUST PAD	1	SIC	∅36X6.5	P2329095	04-2	MOUTH RING	1	RULON	∅27X4.5	P2421462	06	O. RING	1	FKM	∅79.5X2	S80
			CERAMIC		A2221276	04-1	IMPELLER VANE	1	ETFE	∅76X54	P2411045	05-2	OUTER MAGNET	1	FERRITE	∅66X30	P2529488
02	FRONT CASING	1	ETFE	∅91X48.5	P2211043	04	IMPELLER ASS'Y	1	ETFE	∅59X59.5	P2401195	05-1	MAGNET HOUSING	1	ADC-12	∅70X48.5	P2519003
01	MOTOR	100~120V,200~240V , 45W,1∅,2P				03-2	SPINDLE	1	SIC	∅6X50	P2339480	05	OUTER DRIVE RING	1		∅70X63.5	P2509196
									CERAMIC		P2339291	04-5	BEARING	1	SIC		A2469157
NO	PART NAME	Q'TY	MATERIAL	NOTE	DWG. NO.	NO	PART NAME	Q'TY	MATERIAL	NOTE	DWG. NO.				CERAMIC	∅11X31	P2469482
						NO	PART NAME	Q'TY	MATERIAL	NOTE	DWG. NO.	NO	PART NAME	Q'TY	MATERIAL	NOTE	DWG. NO.

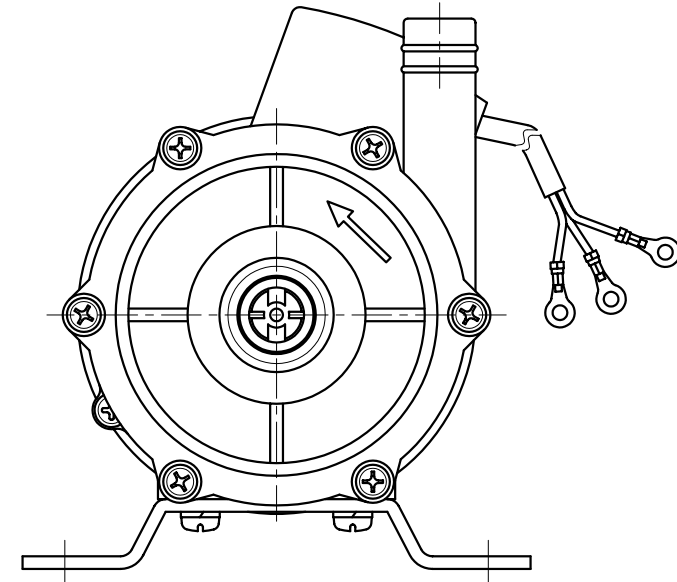
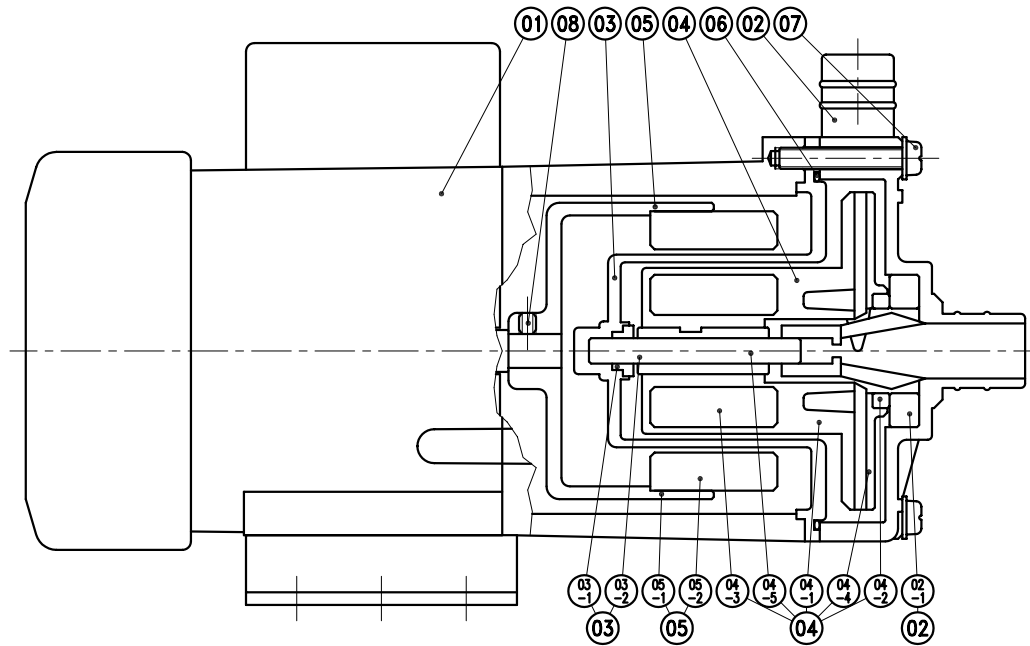

G : 3/4"X 3/4"
NPT : 3/4"X 3/4"

APPROVED		MDL. NAME	NH-100PX-Z-F		
UNIT	MM	CHECK	07 11 02	DWG. NAME	CONSTRUCTION DRAWING
SCALE	4:5	DESIGN	06 16 98	DWG. NO.	B2101008
EDITION	2	DR. BY	07 11 02 BECKY		A3
TPW HONG YUAN		 PAN WORLD CO.,LTD. パンワールド 株式会社			